

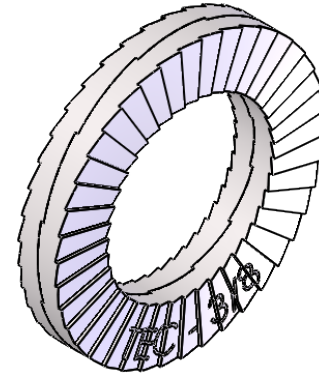

REVISIONS			
REV.	DESCRIPTION	DATE	ECN
A	INITIAL RELEASE	2/27/17	2555
B	HEAT TREAT WAS 480 - 540 HV, .098 WAS .100, .654 WAS .650, .406 WAS .410	3/28/17	2615
C	MATERIAL UPDATE	7/11/2018	3055

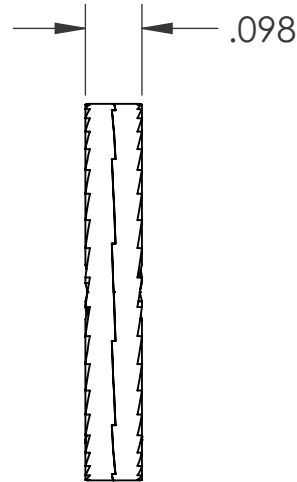
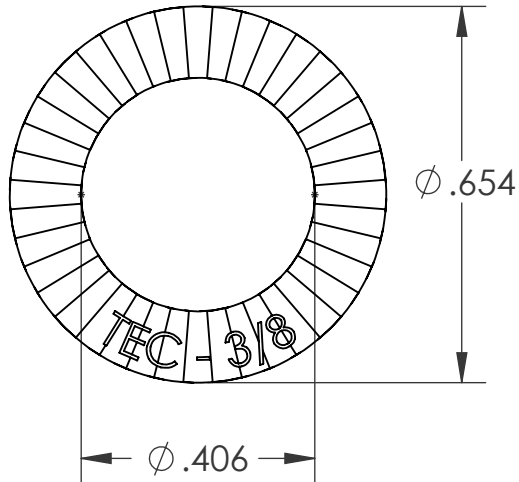

**PROPRIETARY AND CONFIDENTIAL**  
 THIS DRAWING, AND THE INFORMATION CONTAINED HEREIN, ARE THE PROPERTY OF SHEREX AND ARE NOT TO BE USED IN ANY MANNER DETRIMENT TO THE INTEREST OF THE COMPANY.  
 SHEREX FASTENING SOLUTIONS RESERVES THE RIGHT TO REVISE PART/DRAWING WITHOUT NOTICE.

DRAWING NO.:  
**TEC-375**

UNLESS OTHERWISE SPECIFIED:		NAME	DATE	
DIMENSIONS ARE IN INCHES TOLERANCES: ANGULAR: MACH ± 1 BEND ± 1 I.D. TOLERANCE: ± .008 O.D. TOLERANCE: ± .008 THICKNESS TOLERANCE: ± .01		DRAWN	MTB	
INTERPRET GEOMETRIC TOLERANCING PER: ASME Y14.5M-1994		ENG APPR.	JVK	2/27/17
MATERIAL		MFG APPR.		
SCM435 OR 4130 STEEL, HT: THROUGH HARDEN 465 HV MIN		Q.A.		
FINISH		COMMENTS:		
DELTA PROTEKT BASE COAT (KL100) & TOP COAT (VH302GZ)		E-mail: info@disc-lock.com www.disc-lock.com Phone: 866-474-3739 Fax: 716-875-0358		
DO NOT SCALE DRAWING		DESCRIPTION:		
		TEC WASHER GLUED PAIR 3/8"		
		SIZE	PART NO.:	REV
		<b>A</b>	TEC-3/8	<b>C</b>
		SCALE: 3:1	WEIGHT:	SHEET 1 OF 1